



Precision: 0.02mm



Working Range:
400mm



Payload: 1.5kg



DOBOT

DOBOT M1 is a cost-effective intelligent robotic arm for light industry. With high precision, wide working range, complete functions and secondary development, it provides users more ways to use. M1 can realize multiple functions of assembly line work such as soldering, visual recognition and PCB plug-in, helping to construct the intelligent industrial system. No complex installation is required, M1 can be connected just in one step.

Technical specification

Reach	400 mm
Payload	1,5 kg
Max. reach of rear arm	-85° to 85°
Max. reach of forearm	-135° to 135°
End effector rotation	-360° to 360°
Max. speed	180°/s
Max. speed in Z axis	1 m/s
Repeatability	0,02 mm
Power	100V ~ 240 V, 50 ~ 60 Hz
System	Linux
Communication interface	Ethernet, RS-232C
I/O	22 digital outputs 24 digital inputs

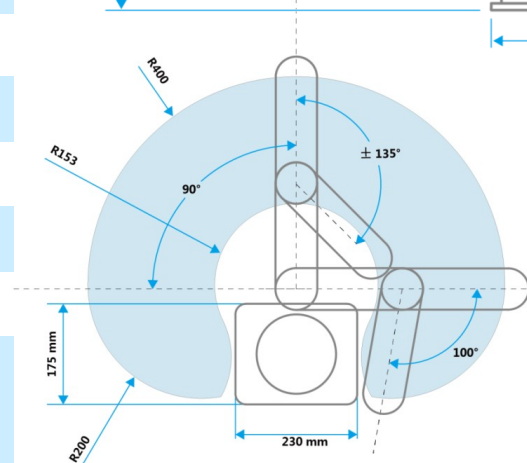
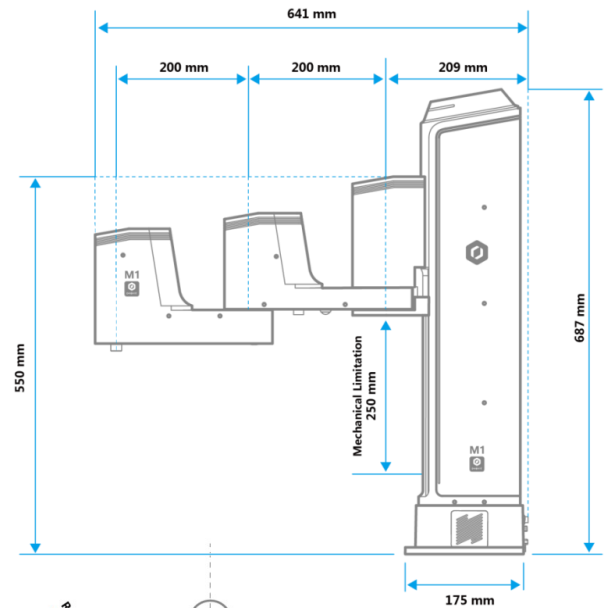

PRŮMYSLOVÉ A EDUKATIVNÍ
ROBOTY



ControlTech

Ovčáry 297, 280 02 Ovčáry, www.controltech.cz, +420 607 170 914, pvladyka@controltech.cz



Authorised
Distributor

A ROCKWELL AUTOMATION PARTNER